

ARP A-Fence



BALCONY DIVIDER

Specification Datasheet

INTERLOCKING OPTION

Aluminium balcony dividers offer effective privacy for shared balconies and terraces without blocking light. Made from durable, corrosion-resistant aluminium, they require minimal maintenance and are easy to clean. Available in various styles, they enhance both privacy and property value. Our provided renders showcase their effectiveness and aesthetic appeal, making them a practical choice for any project.

A2-s1, d0
A2fl-s1
FIRE
RATED

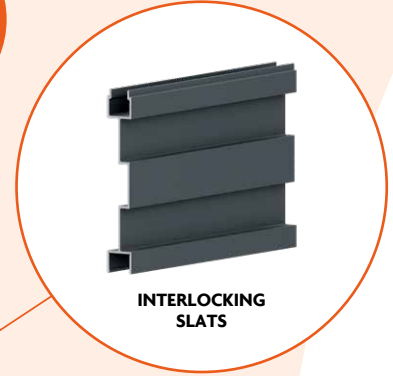

INTERLOCKING SLATS

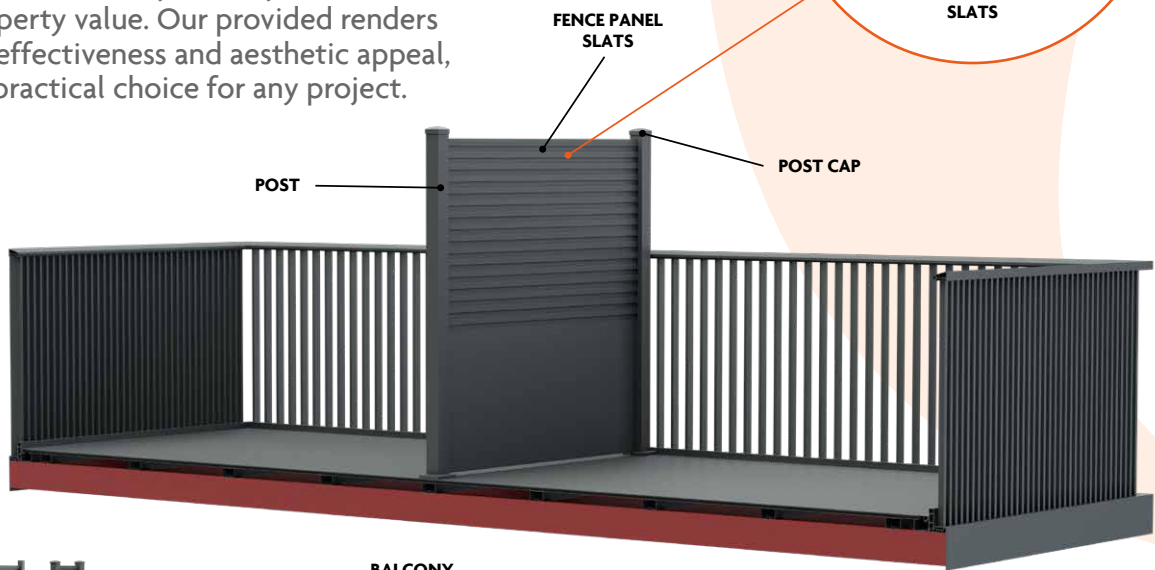

Dimensions

SLAT PROFILE

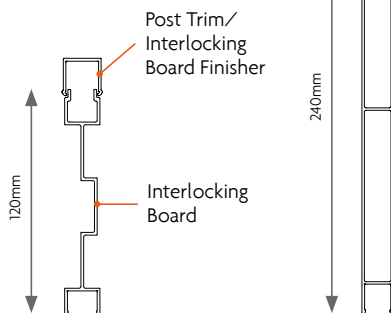

Benefits include:

- 30 year guarantee
- A2-s1, d0 Fire Rated
- 1.8m span between posts
- Simple fixing for hassle free installation
- Modular system
- Available in Textured Anthracite Grey 7016 or Jet Black 9005

ARP A-Fence GATE

**MADE IN
BRITAIN**

Specification Datasheet

**A2-s1, d0
A2fl-s1
FIRE
RATED**

Our aluminium gates offer an ideal solution for adding privacy and easy access to outdoor areas like balconies, terraces, and garden spaces. Designed to integrate seamlessly with the A-Fence system. These gates bring a modern, cohesive look to your property. Constructed from durable, powder-coated aluminium, they are built to last and require minimal maintenance, making them a smart choice for entrances and storage areas.

Dimensions

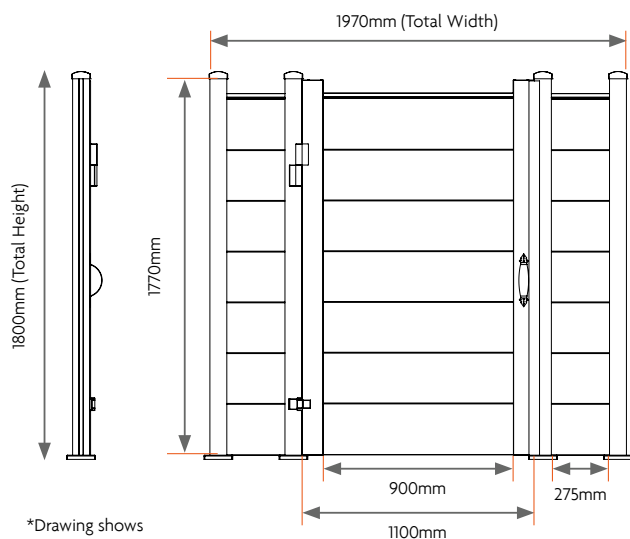

**FULLY
MODULAR
DESIGN**



**A-Fence Gates can also be
used for entrances, storage
spaces, and more**

Benefits include:

- 30 year guarantee
- A2-s1, d0 Fire Rated
- 1100mm width between post
- Simple fixing for hassle free installation
- Modular system
- Available in Textured Anthracite Grey 7016 or Jet Black 9005

ARP
A-RATED PRODUCTS

ARP A-Fence FENCE PANELS



Specification Datasheet

5
PROFILE
OPTIONS

**A2-s1, d0
A2fl-s1
FIRE
RATED**

SLATTED OPTION

A choice of 5 profile options allows you to make your divider or fencing solutions unique with all options interchangeable. Giving you complete flexibility in your design.

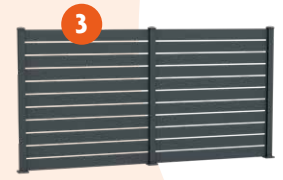
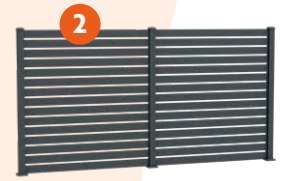
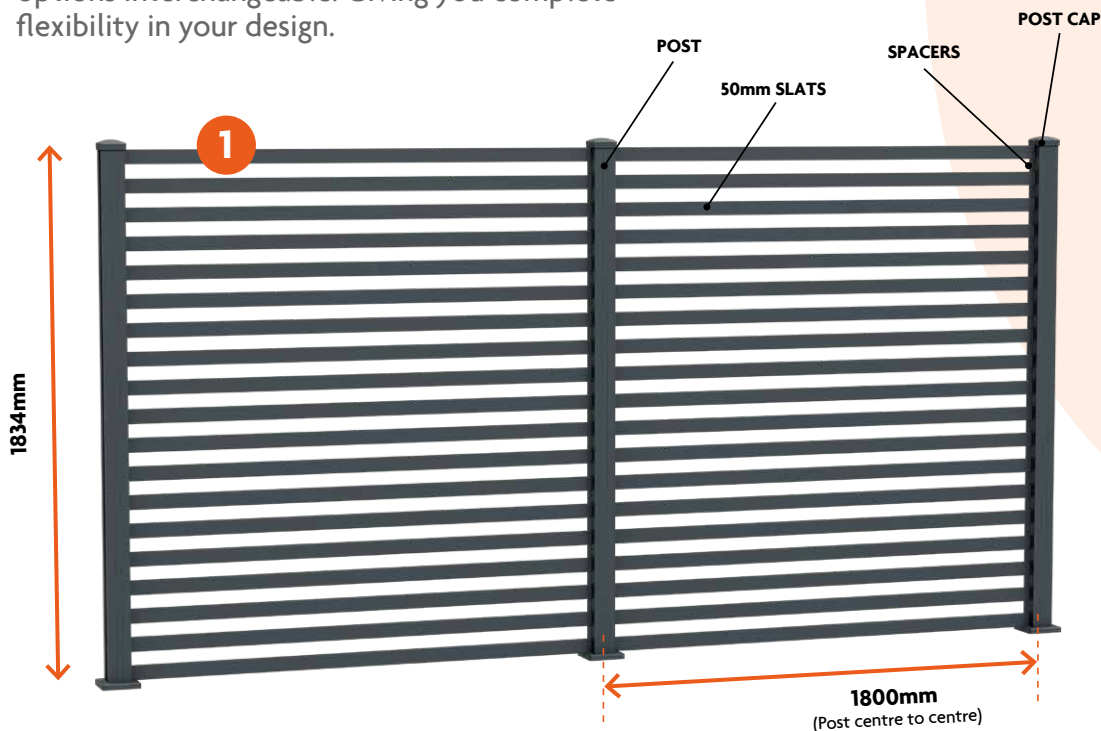
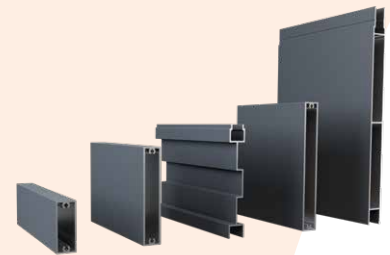

Dimensions

SLAT PROFILES

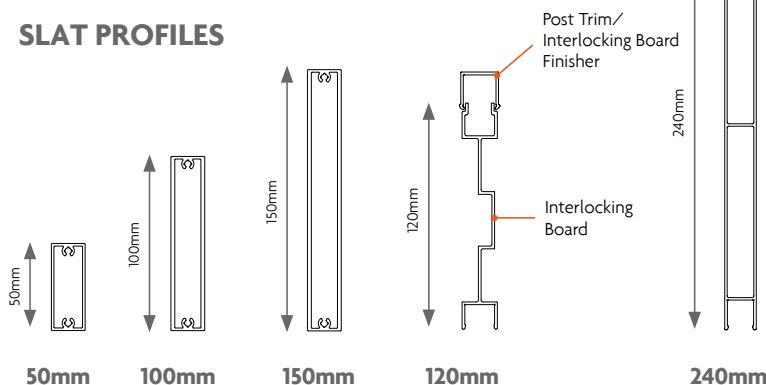

Benefits include:

- 30 year guarantee
- A2-s1, d0 Fire Rated
- 1.8m span between posts
- Simple fixing for hassle free installation
- Modular system
- Available in Textured Anthracite Grey 7016 or Jet Black 9005



Product Specification

- Fire resistant: A2-s1, d0
- Coating thickness - 60-80 microns
- Impact test - with an energy of 2.5kN to ensure that the coating adheres to the substrate to EN ISO 6272 / ASTM D2794
- Bend test - on 5mm mandrel to ensure adhesion after bending to EN ISO 1519
- Machu Test (accelerated corrosion test) - in a solution made up of sodium chloride acetic acid and hydrogen peroxide at 37 °C Duration 48 hours
- Qualicoat 2.4.1. - cross hatch cuts are made at 2mm spacings with one being at 90 degrees to the other cut, tape is applied left for 2 minutes and removed to check for adhesion of paint (EN ISO 2409 2013)
- Qualicoat 2.18 - sawing and drilling test to ensure no flaking after cutting (using sharp tools)
- Acid salt spray test - ISO 9227
- EN ISO 3231 - Resistance to humid atmospheres containing Sulphur Dioxide
- EN ISO 11341 - Accelerated weathering test
- EN ISO 20810 - Natural weathering test (Florida Test) (Carried out on Powder Type)
- EN ISO 12206-1 - Resistance to mortar (Carried out on powder type)
- EN ISO 6270 – 2 - Constant climate condensation water test.

Protective Finish

The A-Fence is coloured using the Qualicoat powder coating finish. Qualicoat is a quality label organisation committed to maintaining and promoting the quality of coating on aluminium and its alloys for architectural applications.

Installation

A-Fences simple fixing system with minimal parts allows for speedy installation on-site.

Construction

The A-Fence is constructed completely from 100% aluminium (6063 T6 grade), up to 67% of which has been recycled to make these joists eco-friendly and much better for the environment.

Maintenance

Due to the fact that AliRail is aluminium and finished using the 7 stage Qualicoat system, little or no maintenance is required. General grime can be removed simply with a damp, lint-free cloth or mop with warm soapy water.

Colour Options

Available finishes include our 2 standard colours, (RAL 7016 & 9005) all in a sleek powder-coat, providing a range of aesthetically pleasing options to suit any property.



ANTHRACITE
GREY
RAL 7016



JET BLACK
RAL 9005

Warranty

The A-Fence is supplied with a **30 year warranty** against splitting, cracking, warping, splintering, rotting, twisting and material or manufacturing defects. It has a minimum **60 year life expectancy**.



A2-s1, d0 & A2fl-s1
FIRE RATED



ALL
ALUMINIUM



HEAT
RESISTANT



QUICK AND EASY
TO INSTALL



LOW
MAINTENANCE



RECYCLABLE



STABLE IN ALL
WEATHER
CONDITIONS

Email: info@aratedproducts.co.uk
www.aratedproducts.co.uk

ARP
A-RATED PRODUCTS